

Radial Lead Capacitors

Marking and Ordering information

Marking information

All encapsulated capacitors are marked with:- Capacitance value, tolerance, rated d.c. voltage, dielectric, and where size permits Syfer logo.

Example: 1000pF ±10% 50V 2X1 dielectric

1N00
K C B

Capacitance:

Code	Capacitance
3P00	3pF
10P0	10pF
100P	100pF
1N00	1000pF
10N0	10nF
1U00	1µF

Tolerance:

Code	Tolerance
C	±0.25pF
D	±0.5pF
F	±1.0pF or ±1%
G	±2%
J	±5%
K	±10%
M	±20%

Dielectric code

Dielectric		Classes		
Class	Code	CECC	EIA	MIL
Ultra stable	C	1B/CG	COG(NPO)	CG/(BP)
Stable	X	2R1	X7R	
To special order				
Stable	B	2X1		BX
Stable	R	2C1		BZ

Rated voltage d.c.

Code	Voltage
C	50
D	63
E	100
F	200
Q	500
Z	1KV
M	2KV
P	3KV
S	4KV
U	5KV

Ordering information for Radial Lead Capacitors

Example: 8111M 100 0102 J C

Type No/Size ref _____

Voltage d.c. _____

050 = 50 Volts	1K0 = 1KV
063 = 63 Volts	2K0 = 2KV
100 = 100 Volts	3K0 = 3KV
200 = 200 Volts	4K0 = 4KV
500 = 500 Volts	5K0 = 5KV

Capacitance (pF) _____

First digit - 0
 Second digit - First significant figure of capacitance value
 Third digit - Second significant figure of capacitance value
 Fourth digit - Number of zeros following.
 eg. 0102 = 1000pF.
 For values below 10pF insert a P for the decimal point.
 eg. 8P20 = 8.2pF

Suffix code. The remaining alpha/numeric digits are used to denote variation from the standard products of customer special requirements (electrical, packing, mechanical, environmental, coding etc.)
 All products with "C42" as the suffix code are RoHS compliant. Products with other suffix codes may be RoHS compliant, please contact sales office for details.

Dielectric code

Dielectric		Classes		
Class	Code	CECC	EIA	MIL
Ultra stable	C	1B/CG	COG(NPO)	CG/(BP)
Stable	X	2R1	X7R	
To special order				
Stable	B	2X1		BX
Stable	R	2C1		BZ

Capacitance tolerance code

Ultra stable class		Stable class		
Cr < 10pF	± 0.25 pF	C	± 5%	J
	± 0.5 pF	D	± 10%	K
Cr ≥ 10pF	± 1%	F	± 20%	M
	± 2%	G		
	± 5%	J		
	± 10%	K		

Radial Lead Capacitors

Dipped

COG/X7R

Dimensions

	Size	CECC	Width (X) max mm inches	Height (Y) max mm inches	Thickness (Z) max mm inches	Lead Space (S) mm inches	Lead Length (L) min mm inches	Lead Diameter (d) mm inches
	Case	Pattern						

Dipped Radial

8111M	A	A	3.81 0.15	5.31 0.21	2.54 0.10	2.54±0.4 0.1±0.016	5.0 0.2	0.5±0.05 0.02±0.002
8111N	F	B	3.81 0.15	5.31 0.21	2.54 0.10	5.08±0.4 0.2±0.016	5.0 0.2	0.5±0.05 0.02±0.002
8121M	B	A	5.08 0.20	6.58 0.26	3.18 0.125	2.54±0.4 0.1±0.016	5.0 0.2	0.5±0.05 0.02±0.002
8121N	C	B	5.08 0.20	6.58 0.26	3.18 0.125	5.08±0.4 0.2±0.016	5.0 0.2	0.5±0.05 0.02±0.002
8131M	D	A	7.62 0.30	9.12 0.36	3.81 0.15	5.08±0.4 0.2±0.016	5.0 0.2	0.5±0.05 0.02±0.002
8141M	H	A	10.16 0.40	11.66 0.46	3.81 0.15	5.08±0.4 0.2±0.016	5.0 0.2	0.5±0.05 0.02±0.002
8151M	J	A	12.70 0.50	14.20 0.56	5.08 0.20	10.1±0.4 0.4±0.016	5.0 0.2	0.6±0.05 0.025±0.002
8161M			18.50 0.73	16.50 0.65	6.00 0.24	14.5±0.5 0.57±0.02	5.0 0.2	0.6±0.05 0.025±0.002
8171M			25.00 0.98	20.00 0.79	6.00 0.24	20.5±0.5 0.81±0.02	5.0 0.2	0.6±0.05 0.025±0.002

Dipped Radial

Pattern A

Pattern B

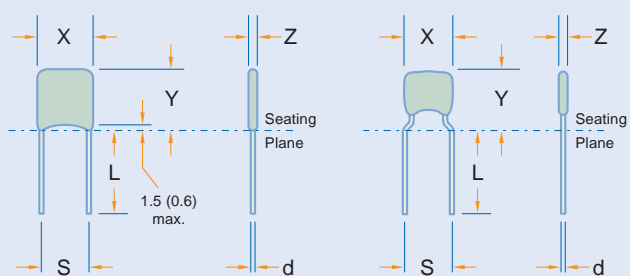

Radial Lead Capacitors

Loose capacitors cropped and snap-in leads

Cropped Leads

Cropped leads between 4.0 (0.157) and 30.0 (1.18) are available to special order. Some of the preferred codes are listed below, together with the appropriate suffix code. Dimensions as for standard product except as specified.

Dimensions mm (inches)

Suffix code - AE3
All radial ranges

Lead length (L)
 6 ± 1 (0.236 \pm 0.04)
from seating plane

Suffix code - AE4
All radial ranges

Lead length (L)
 4 ± 1 (0.162 \pm 0.04)
from seating plane

Suffix code - AD7
All radial ranges

Lead length (L)
 5 ± 1 (0.2 \pm 0.04)
from seating plane

Suffix code - AD5
All radial ranges

Lead length (L)
 10 ± 1 (0.4 \pm 0.04)
from seating plane

Snap in leads

Various forms of snap in leads (preformed) are available to special order, some of the preferred suffix codes are listed below. Dimensions as for standard product except as specified.

Suffix code - AD1

For PCB holes 0.9mm diameter
Types 8121N and 8131M

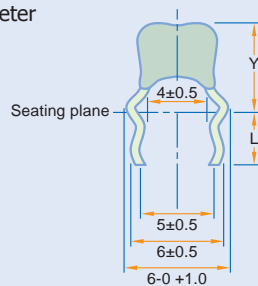

Dimensions

Y = 8121N 8 (0.315) Max
8131M 10 (0.394) Max
L = Min: 2.75 (0.108)
Max: 3.50 (0.138)

Suffix code - AD2

For PCB holes 1.2mm diameter
Types 8131M

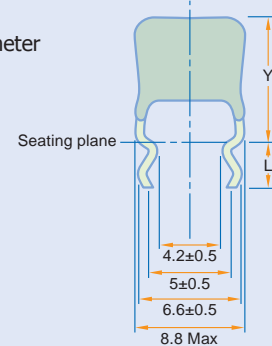

Dimensions

Y = 10 (0.294) Max
L = Min: 2.75 (0.108)
Max: 3.50 (0.138)

Suffix code - AD3

For PCB holes 1.2mm diameter
Types 8121N

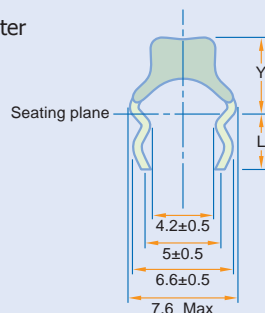

Dimensions

Y = 8 (0.315) Max
L = Min: 2.75 (0.108)
Max: 3.50 (0.138)

Suffix code - A07

For PCB holes 0.8 to 0.97mm diameter
Types 8121M

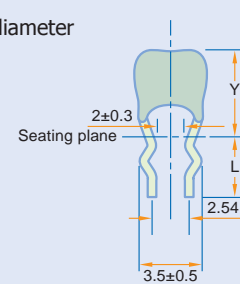

Dimensions

Y = 6.58 (0.259) Max
L = Min: 2.75 (0.108)
Max: 3.50 (0.138)

Radial Lead Capacitors

Bandoliered Packaging Information

A maximum of 3 consecutive components may be missing from the bandolier, followed by at least 6 filled positions.

Components missing from the bandolier are included in the total quantity, whereby the number of missing components may not exceed 0.25% of this total per packing module.

At the beginning and end of a reel the bandolier will exhibit at least 10 blank positions.

Minimum pull strength of product from tape = 5N.

Each reel/carton is provided with a label showing the:

Manufacturer, product style, batch identification, quantity and date code.

Labelling with bar codes (code 39) is available on request.

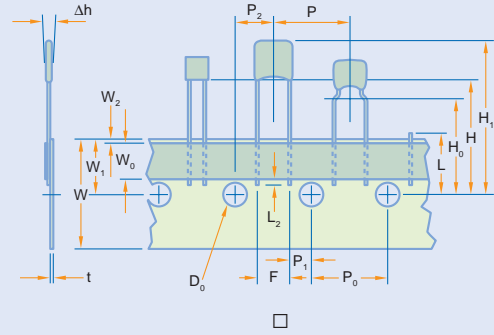

Dimensions mm (inches)

Description	Symbol	2.5mm lead space	5mm lead space	Tolerance
Lead wire diameter	d	0.5 (0.02), 0.6 (0.025)	0.5 (0.02), 0.6 (0.025)	±0.05 (0.002)
Component pitch	P	12.7 (0.5)	12.7 (0.5)	1.00 (0.04)
Feed hole pitch	P ₀	12.7 (0.5)	12.7 (0.5)	±0.30 (0.01)
Feed hole centre to lead	P ₁	5.08 (0.2)	3.81 (0.15)	±0.70 (0.03)
Feed hole centre to component	P ₂	6.35 (0.25)	6.35 (0.25)	±0.70 (0.03)
Lead spacing	F	2.54 (0.10)	5.08 (0.20)	+0.6 (0.02) -0.1 (0.004)
Component alignment	Dh	0	0	±2.00(0.08)
Tape width	W	18.0 (0.70)	18.0 (0.70)	+1.00 (0.04) -0.50 (0.02)
Hold down tape width	W ₀	6.0 (0.23)	6.0 (0.23)	±0.30 (0.01)
Hole position	W ₁	9.0 (0.35)	9.0 (0.35)	±0.50 (0.02)
Hold down tape position	W ₂	0.50 (0.02)	0.50 (0.02)	Max
Height to seating plane from tape centre (straight leads) (2)	H	16 (0.63) to 20 (0.79)	16 (0.63) to 20 (0.79)	As required
Height to seating plane from tape centre (formed leads) (2)	H ₀	16 (0.63) to 20 (0.79)	16 (0.63) to 20 (0.79)	As required
Height to top of component from tape centre	H ₁	32.2 (1.26)	32.2 (1.26)	Max
Feed hole diameter	D ₀	4.0 (0.16)	4.0 (0.16)	±0.20 (0.008)
Carrier tape plus adhesive tape thickness	t	0.7 (0.03)	0.7 (0.03)	±0.20 (0.008)
Carrier tape thickness	-	0.5 (0.02)	0.5 (0.02)	±0.10 (0.004)
Cut out component snipped lead length from tape centre	L	11.0 (0.43)	11.0 (0.43)	Max
Lead wire protrusion from hold down	L ₂	2.0 (0.08)	2.0 (0.08)	Max

Bandoliered reels

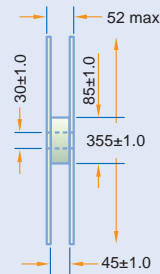
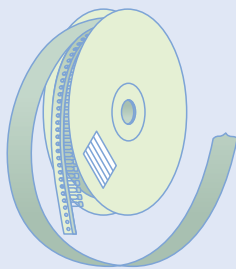

The adhesive tape faces outwards. The dispensing direction is as shown. For the protection of the components a paper inlay is inserted between the windings of the bandolier. At the end of the bandolier this paper inlay continues for at least a further two rotations.

Bandoliered ammo packing

2 carton sizes

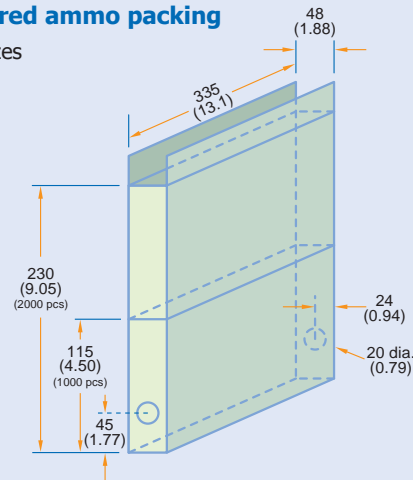

Radial Lead Capacitors

Bandoliered suffix codes

Dipped radial leaded with 2.54 and 5.08mm lead spacing can be supplied bandoliered on reels or in ammo boxes to special order. Some of the preferred suffix codes for bandoliered products are given below.

For bandoliered products the minimum order quantity, pieces, is specified in the tables below, larger orders must be in multiples of this quantity.

Dipped – straight and formed leads

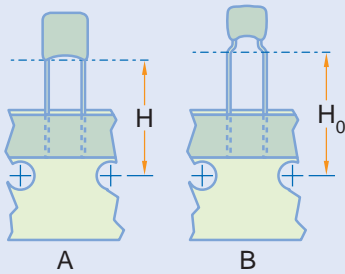

Product code	Lead style	Diagram	H	H ₀	Suffix code		
					Reel 2500pcs	AMMO pack 1000pcs 2000pcs	
8111M	Straight 2.54 crs	A	19±1	–	C01	C02	C11
8111M	Straight 2.54 crs	A	16±0.5	–	C30	C31	C32
8111N	Formed 5.08 crs	B	–	16±0.5	C01	C02	C11
8121M	Straight 2.54 crs	A	19±1	–	C01	C02	C11
8121M	Straight 2.54 crs	A	16±0.5	–	C30	C31	C32
8121N	Formed 5.08 crs	B	–	16±0.5	C01	C02	C11
8131M	Straight 5.08 crs	A	19±1	–	C01	C02	C11
8131M	Straight 5.08 crs	A	16±0.5	–	C30	C31	C32

Dipped – stand-off lead form

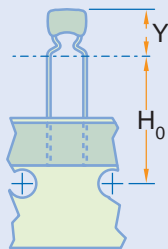

Product code	Lead style	Y max	H ₀	Suffix code		
				Reel 2500pcs	AMMO pack 1000pcs 2000pcs	
8111N	Formed 5.08 crs	7.5	16±0.5	C12	C23	C22
8111N	Formed 5.08 crs	7.5	19±1	C13	C25	C24
8121N	Formed 5.08 crs	8.5	16±0.5	C12	C23	C22
8121N	Formed 5.08 crs	8.5	19±1	C13	C25	C24

This style has been developed to provide a meniscus-free seating plane with a stress relieving form for auto-insertion.

Dipped Radial Lead Capacitors

Ultra-stable Dielectric

COG

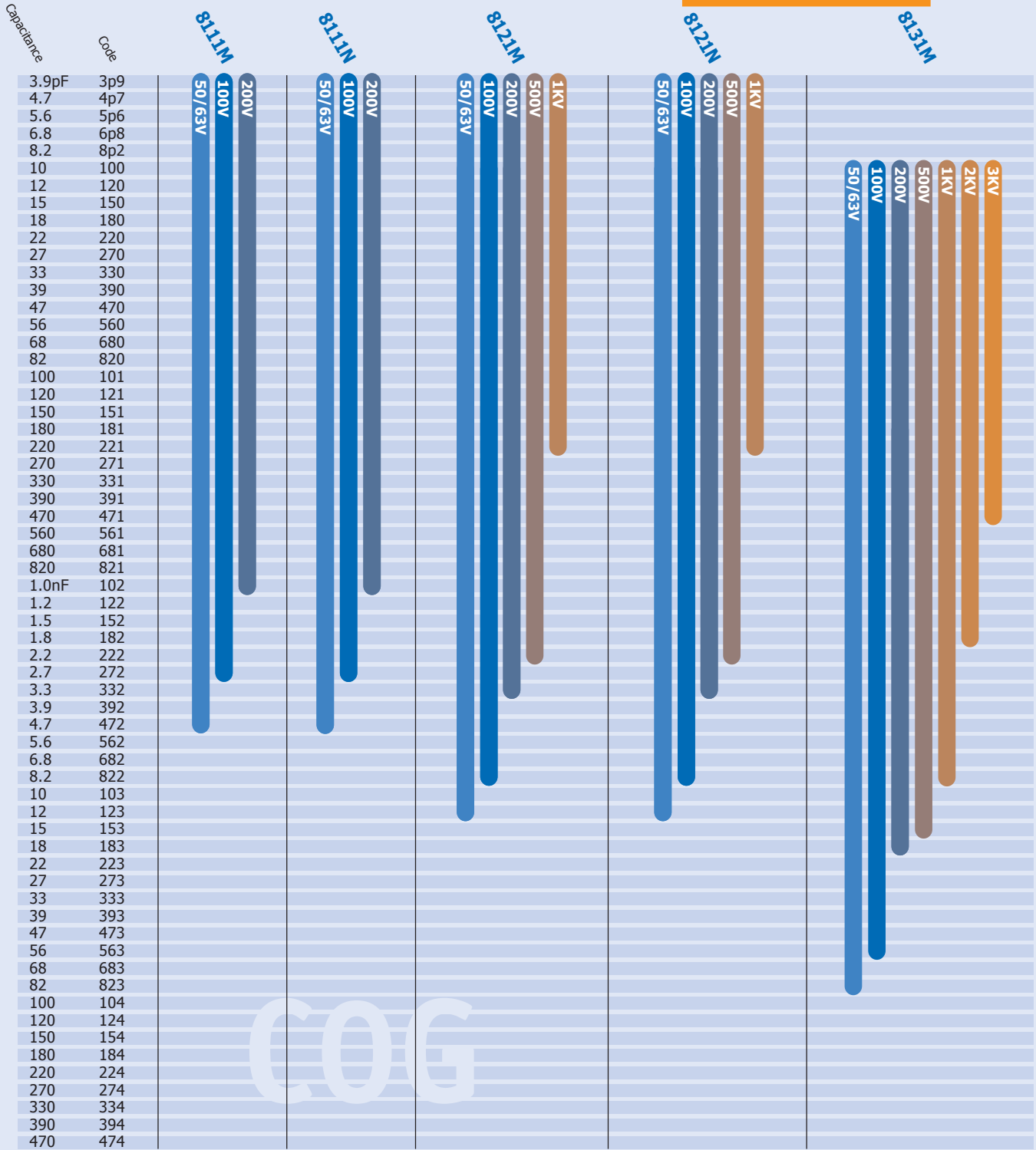

Dipped Radial Lead Capacitors

Ultra-stable Dielectric

COG

Capacitance	Code	8141M	8151M	8161M	8171M
3.9pF	3p9				
4.7	4p7				
5.6	5p6				
6.8	6p8				
8.2	8p2				
10	100				
12	120				
15	150				
18	180				
22	220				
27	270				
33	330				
39	390				
47	470				
56	560				
68	680				
82	820				
100	101				
120	121				
150	151				
180	181				
220	221				
270	271				
330	331				
390	391				
470	471				
560	561				
680	681				
820	821				
1.0nF	102				
1.2	122				
1.5	152				
1.8	182				
2.2	222				
2.7	272				
3.3	332				
3.9	392				
4.7	472				
5.6	562				
6.8	682				
8.2	822				
10	103				
12	123				
15	153				
18	183				
22	223				
27	273				
33	333				
39	393				
47	473				
56	563				
68	683				
82	823				
100	104				
120	124				
150	154				
180	184				
220	224				
270	274				
330	334				
390	394				
470	474				

notes

1. Either pattern A or B may be supplied with the stated lead space (S) and wire diameter (d) and within the maximum dimension of the specified type.
2. For sizes 8111, 8121 and 8131 at 50/63, 100 and 200V the capacitance values 3.9pF to 27nF can be supplied CECC Approved.

Dipped Radial Lead Capacitors

Stable Dielectric

X7R

Capacitance	Code	8111M	8111N	8121M	8121N	8131M
100pF	101					
120	121					
150	151					
180	181					
220	221					
270	271					
330	331					
390	391					
470	471					
560	561					
680	681					
820	821					
1.0nF	102					
1.2	122					
1.5	152					
1.8	182					
2.2	222					
2.7	272					
3.3	332					
3.9	392					
4.7	472					
5.6	562					
6.8	682					
8.2	822					
10	103					
12	123					
15	153					
18	183					
22	223					
27	273					
33	333					
39	393					
47	473					
56	563					
68	683					
82	823					
100	104					
120	124					
150	154					
180	184					
220	224					
270	274					
330	334					
390	394					
470	474					
560	564					
680	684					
820	824					
1.0μF	105					
1.2	125					
1.5	155					
1.8	185					
2.2	225					
2.7	275					
3.3	335					
3.9	395					
4.7	475					
5.6	565					
6.8	685					
5.6	565					
6.8	685					
8.2	825					

X7R

Dipped Radial Lead Capacitors

Stable Dielectric

X7R

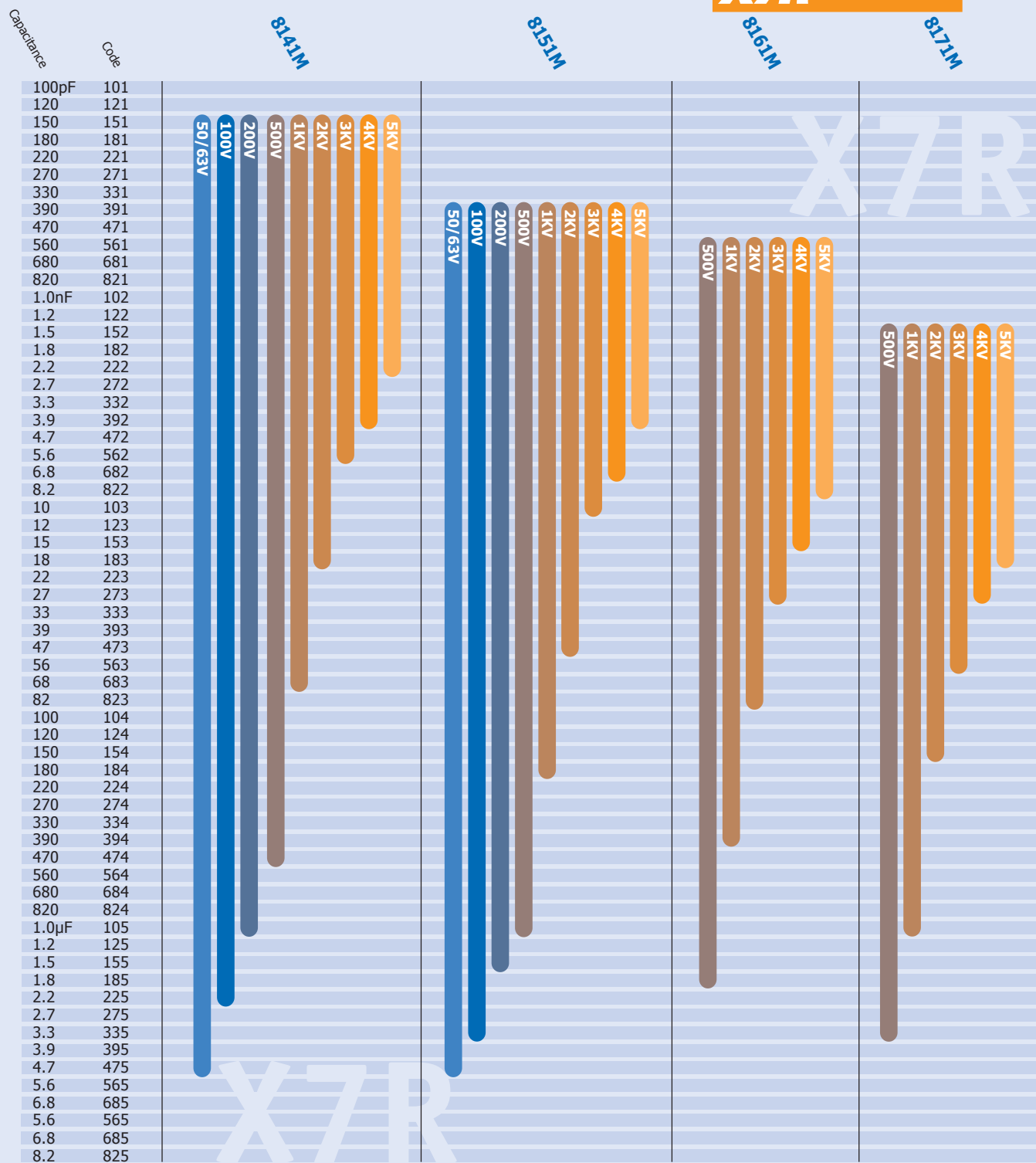

notes

1. Either pattern A or B may be supplied with the stated lead space (S) and wire diameter (d) and within the maximum dimension of the specified type.
2. For sizes 8111, 8121 and 8131 at 50/63, 100 and 200V the capacitance values 100pF to 1.0µF can be supplied CECC Approved.